

Product Datasheet

EXP-AH-5G/10G EXP-AH-5GS/10G

Outdoor Heated Emergency Safety Shower

Trace tape heated and pre-insulated floor mounted emergency safety shower with body spray. intended for use where there is a possibility of the water inside the shower freezing due to extreme cold climates. Suitable for both hazardous and non-hazardous environments. Available with galvanised mild steel or 316L stainless steel pipework.

Specifications

MATERIALS OF CONSTRUCTION

PIPEWORK AND FITTINGS (G)	Galvanised mild steel with 150lb medium wall tubulars and fittings
PIPEWORK AND FITTINGS (GS)	316L stainless steel with 150lb medium wall tubulars and fittings
OPERATING VALVES	316L stainless steel
SHOWER SPRAY OUTLET	Machine moulded nylon 6 red shower nozzle
INSULATION & OUTER CASING	Polyurethane foam insulation with a medium density polyethylene impact resistant outer casing
STANDARD FINISH (Stainless steel)	White with green/white safety stripes (alternative colours available)

SERVICES

WATER INLET	1 1/4" Male BSP
DESIGN OPERATING PRESSURE	1.8 to 6 BAR G (26 to 87 PSI) (higher supply pressures accommodated with the incorporation of the optional pressure reducing valve)
HEATING TYPE	Trace tape heated and pre-insulated
HEATING LOAD	42 Watts
ELECTRICAL EQUIPMENT - Non-hazardous	Suitable for use in areas classified as non-hazardous
ELECTRICAL EQUIPMENT - Hazardous	ATEX Zone 1 & 2 Gas Groups IIA and IIB, Temp Class T3 (IIC available)
ELECTRIC SUPPLY	240V Single Phase, 50/60Hz or 110V available
TEST PRESSURE	10.3 BAR G (149 PSI)
MINIMUM FLOW AT OPERATING PRESSURE	Shower/body spray: 125 litres/minute minimum (33 US gallons)

ENVIRONMENTAL OPERATING TEMPERATURE

MINIMUM AMBIENT OPERATING TEMPERATURE	-20° C (-4° F)
MAXIMUM AMBIENT OPERATING TEMPERATURE	35° C (95° F)

OPERATIONAL

SHOWER SPRAY OPERATION	Pull handle (optional foot panel for hands free operation)
------------------------	--

WEIGHTS and DIMENSIONS

DIMENSIONS - STANDARD ORIENTATION (WxDxH)	320mm (12.6in) x 890mm (35in) x 2330mm (91.7in)
WEIGHT (NO OPTIONS)	24kg (53lb)

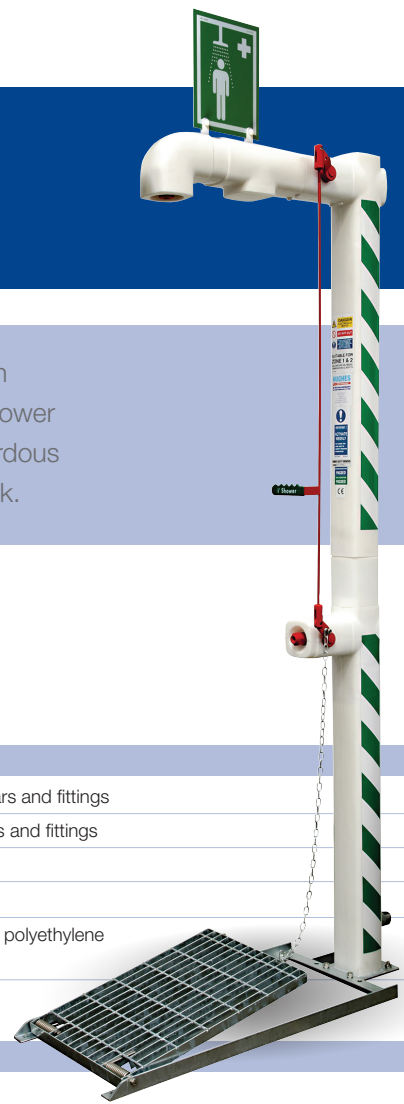

View our Guide to the ANSI/ISEA Z358.1-2014 International Standard for Emergency Eyewash and Shower Equipment at www.hughes-safety.com



EXP-AH-5G/10G
EXP-AH-5GS/10G

Outdoor Heated Emergency Safety Shower

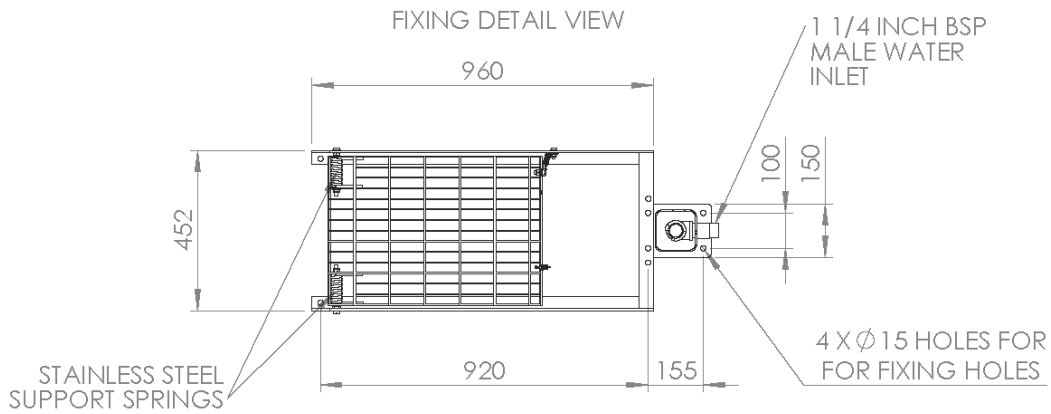
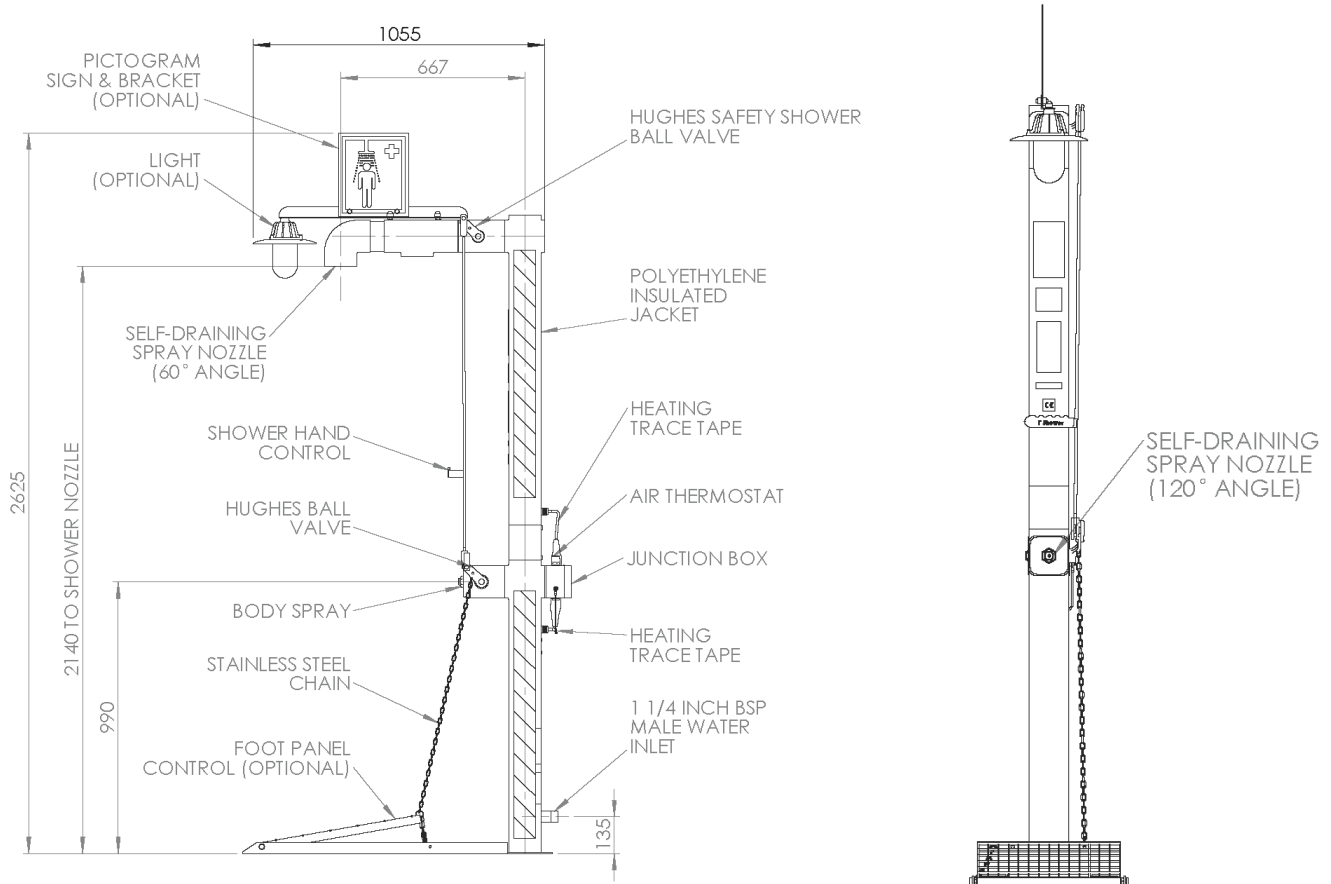

HUGHES



HUGHES-SAFETY.COM

a Justrite® Group Company

Hughes Safety Showers Ltd, Whitefield Road, Bredbury, Stockport SK6 2SS UK.

Email: info@hughes-safety.com

Tel: +44 (0)161 430 6618

Registered No. 0939240. VAT Registration No. 918 5005 32. Hughes Safety Showers Ltd is a Justrite Group Company.

V1.1